

Feline Nuvo®

Fine (& Fun) Feline Furniture®

800-428-8560
 midwesthomes4pets.com
 3142 S. Cowan Rd.
 Muncie, Indiana 47302



Assembly Instructions for Model Number 139C-TN (Cove)

Pour des instructions en français, veuillez visiter : <https://www.midwesthomes4pets.com>.

Para obtener instrucciones en español, por favor visite: <https://www.midwesthomes4pets.com>.

IMPORTANT INFORMATION

Unwrap and remove all parts from the box. Keep the box and packing material until the product is assembled. In case of return or exchange, failure to return product in similar condition as received could result in limited reimbursement. Please save sales receipt as proof of purchase for warranty purposes. Check to ensure you have all the parts below. If you discover any parts are missing, immediately call our toll-free service helpline at 1-800-428-8560 (Monday - Friday 9 a.m. to 4 p.m. EST) or at info@midwesthomes4pets.com.

PARTS IDENTIFICATION

- | | | |
|-------------------|-----------------------------------|---|
| A - Base | G - Pillow | M - Dual Screw w/ Uneven Threads (2.4"/ 60mm) (2) |
| B - Cubby | H - Bolstered Drawstring Pillow | N - Dual Screw w/ Even Threads (2.8"/ 70mm) |
| C - Platform | I - Long Screw (2"/ 50mm) | O - Dome Head Screw (1.8"/ 45mm) |
| D - Long Post (2) | J - Short Screw (1.4"/ 35mm) | P - Tiny Screw (.5"/ 12mm) (2) |
| E - Short Post | K - Washer (1.5"/ 40mm) | Q - Dangle Ball |
| F - Hoop Hammock | L - Small Washer (1.2"/ 32mm) (2) | R - Allen Wrench |

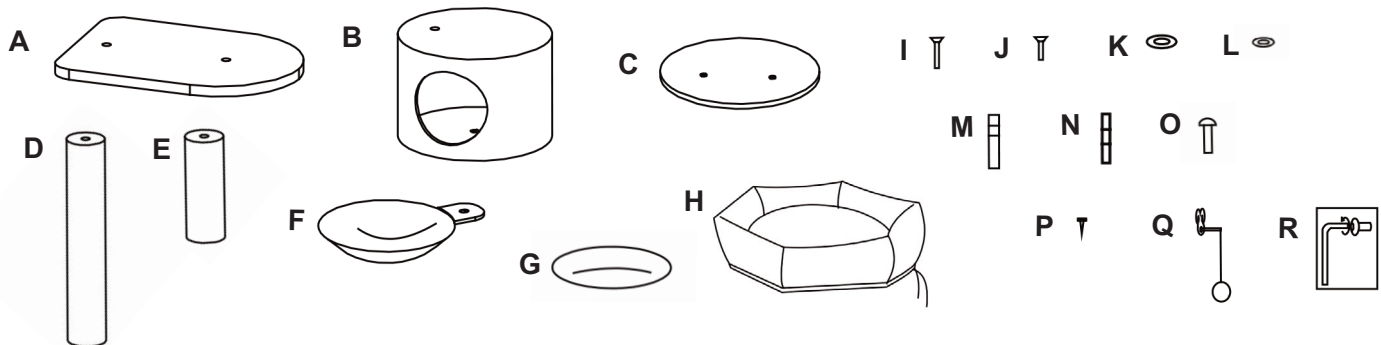

ASSEMBLY INSTRUCTIONS

A Phillips Screwdriver will be needed for assembly.

- Place a Small Washer (L) over the Short Screw (J). Push the Washer and Short Screw up through the bottom of the Base (A). Twist the Cubby (B) onto the screw and secure it to the rounded side of the Base. Place another Small Washer (L) over the Long Screw (I). Push the Washer and Long Screw up through the second hole in the bottom of the Base. Set aside.
- Using two Dual Screws w/ Uneven Threads (M), attach the Short Post (E) and a Long Post (D) to the underside of the Platform (C). Make sure the short threads go into the platform and the long threads go into the posts.

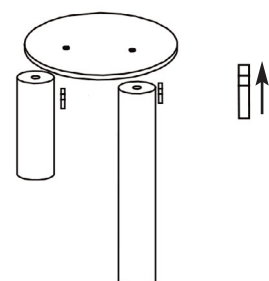
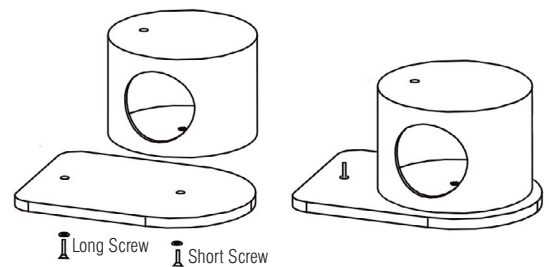

3. Use the Dual Screw w/ Even Threads (N) to connect the Hoop Hammock (F) and the second Long Post (D) to the Short Post already in place. Place the Pillow (G) in the Hoop Hammock.

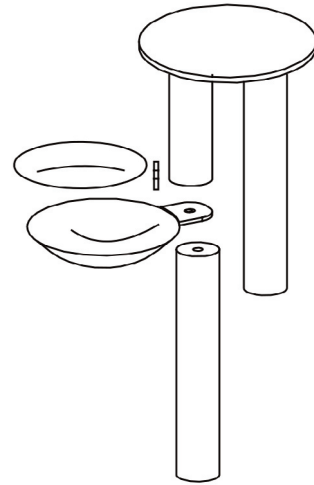

4. Align the assembled Posts with the holes in the Base and the top of the Cubby. Place a Washer (K) on the Dome Head Screw (O) and attach the shorter post to the top of the Cubby. Tighten with the Allen Wrench (R). Secure the longer post to the Base using the screw in place from Step 1. Tighten with the Allen Wrench.

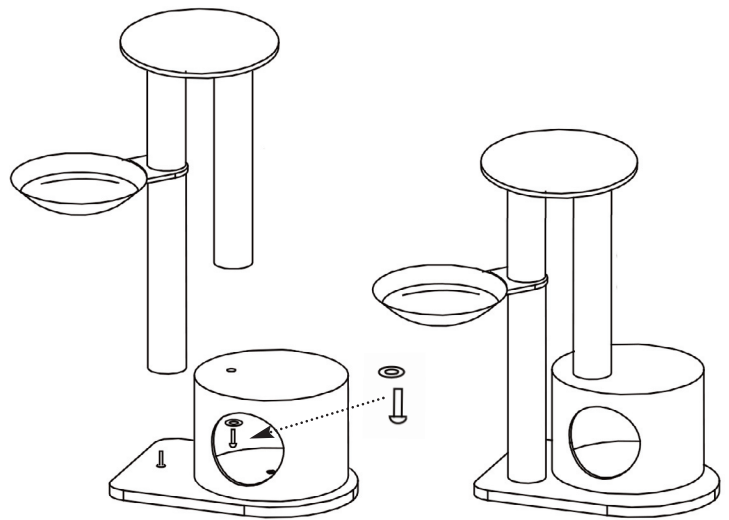

5. Place the Bolstered Pillow (H) on the Platform and secure with the drawstring. With a Phillips screwdriver and the Tiny Screws (P), attach the Dangle Ball (Q) to the post.

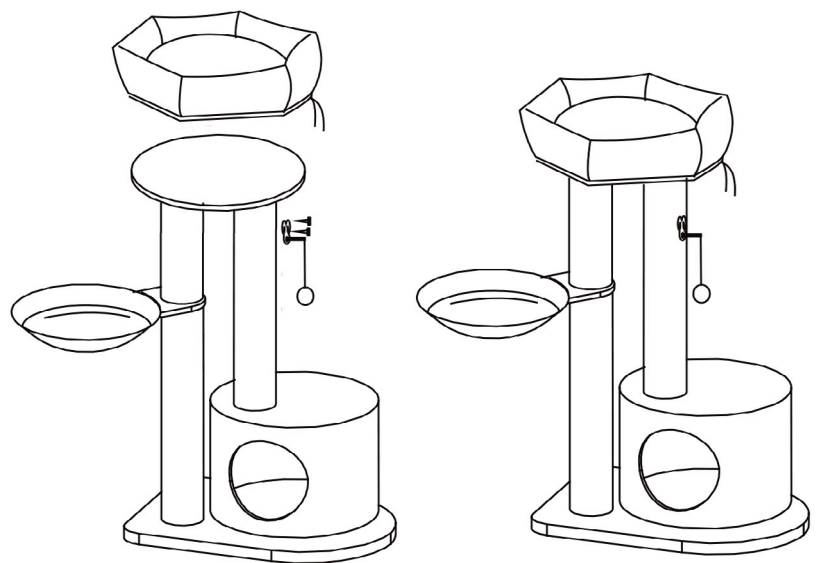

To clean your Feline Nuvo Cat Furniture, wipe with a damp cloth. Do not submerge or spray with water as this will damage the structure.

TOLL-FREE SERVICE HELPLINE: If you have any problems or questions with the assembly of your new Feline Nuvo Cat Furniture, call our Service Helpline at: 1-800-428-8560 between 9:00 a.m. and 4:00 p.m. (EST) Monday through Friday.

LIMITED MANUFACTURER'S WARRANTY

1. For one (1) year from the date of original purchase, MIDWEST Homes For Pets ("MIDWEST") warrants to the purchaser of this pet furniture that, should it prove defective by reason of improper workmanship and/or material, MIDWEST will repair or replace, at its option, any defective part of the pet furniture, without charge for the part or for shipping. Replacement parts are warranted for the remainder of the original period.
2. **THIS WARRANTY DOES NOT COVER** defects in the furniture caused by any animal, any physical abuse to or misuse of the pet furniture, any damage caused by the original purchaser or any third party, or any defects arising or discovered more than one (1) year from the original retail purchase date.
3. **STEPS TO OBTAIN WARRANTY SERVICE:**
 - A. The purchaser must call MIDWEST's HELPLINE, 800-428-8560, to report the alleged defect to a customer service representative or obtain missing parts.
 - B. The customer service representative will determine if the defect is covered by this warranty and, if it is, will authorize and instruct the purchaser in how to obtain corrective action.
 - C. MIDWEST may require the purchaser to present the sales receipt or other proof of purchase prior to authorizing any return or replacement. No returns or replacements will be permitted without proper authorization. If a return or replacement is authorized, you may be requested to return the item to MIDWEST or to make the item available for pick-up by MIDWEST.
4. **ANY EXPRESS WARRANTY NOT PROVIDED IN THIS WARRANTY DOCUMENT, AND ANY REMEDY FOR BREACH OF CONTRACT THAT, BUT FOR THIS PROVISION, MIGHT ARISE BY IMPLICATION OR OPERATION OF LAW, IS HEREBY EXCLUDED AND DISCLAIMED. THE IMPLIED WARRANTIES OF MERCHANTABILITY AND OF FITNESS FOR ANY PARTICULAR PURPOSE ARE EXPRESSLY LIMITED TO A TERM OF ONE (1) YEAR. SOME STATES DO NOT ALLOW LIMITATIONS ON HOW LONG AN IMPLIED WARRANTY LASTS, SO THE ABOVE LIMITATIONS MAY NOT APPLY TO YOU.**
5. **UNDER NO CIRCUMSTANCES SHALL MIDWEST BE LIABLE TO PURCHASER OR ANY OTHER PERSON FOR ANY SPECIAL, INCIDENTAL OR CONSEQUENTIAL DAMAGES, WHETHER ARISING OUT OF BREACH OF WARRANTY, BREACH OF CONTRACT OR OTHERWISE, SOME STATES DO NOT ALLOW THE EXCLUSION OR LIMITATIONS OF INCIDENTAL OR CONSEQUENTIAL DAMAGES, SO THE ABOVE LIMITATIONS OR EXCLUSION MAY NOT APPLY TO YOU.**
6. This warranty gives you specific legal rights, and you may also have other rights which vary from state to state.

For a Complete Listing of Products
Cat Furniture • Pet Beds
Cat Playpens • Ex Pens • Accessories . . .
- Come Visit Our Website
www.midwesthomes4pets.com

